

AN AUSTRALIAN FIRST, MELROSE CRANES PRESENT

1006

THE WORLD'S
STRONGEST
MINI CRANE



UNIC

CAPACITY: 10.0t x 3.0m MAXIMUM LIFTING HEIGHT: 22.8m MAXIMUM WORKING RADIUS: 21.9m

FLY JIB - MAXIMUM LIFTING HEIGHT: 30.7m FLY JIB - MAXIMUM WORKING RADIUS: 24.3m

URW-1006

10.0t

- Total width 2.0m
- Max working radius 21.9m (24.3m with fly jib)
- Max working height 22.8m (30.7m with fly jib)
- Diesel powered and optional integrated mains electric
- Zero length increase with electric option
- Radio remote control with feedback display as standard
- Working area limitation
- High resolution colour SLI display
- Stowable hydraulic fly jib
- Searcher hook (optional)
- Slew limitation (optional)
- Intelligent throttle activation for economy and ecology

Max Boom Length 23.1m

Capacity 10.0t x 3.0m

Max Lifting Height 22.8m
(30.7m with extension jib)

Weight 14000 kg



The mightiest of the world's mini cranes, the UNIC URW-1006 boasts an unrivalled 10 tonnes of lifting power.

The UNIC URW-1006 offers a generous 30.7 metre lifting height and 24.3 metre working radius, yet at only 2 metres wide still retains class-beating minimal dimensions for working in restricted spaces.

This versatile mini crane also has a unique pick and carry function which enables it to travel with loads up to 1.5 tonnes. Its configurable outriggers provide maximum stability when lifting on uneven surfaces thanks to their full safety interlocking system.

The UNIC URW-1006 is also fitted with a state-of-the-art safe load indicator which gives operator feedback on a high-resolution colour LCD screen for safer lifting.

RADIO REMOTE CONTROL WITH FEEDBACK DISPLAY



Optional radio remote control with digital feedback



Shockless damping system for smooth stop when operated via remote control

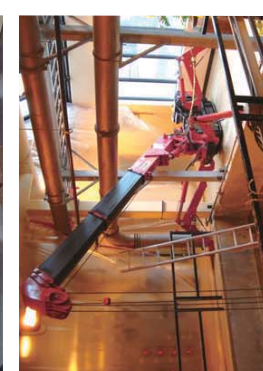

MINI SPIDER CRANE

UNIC

DIMENSIONS

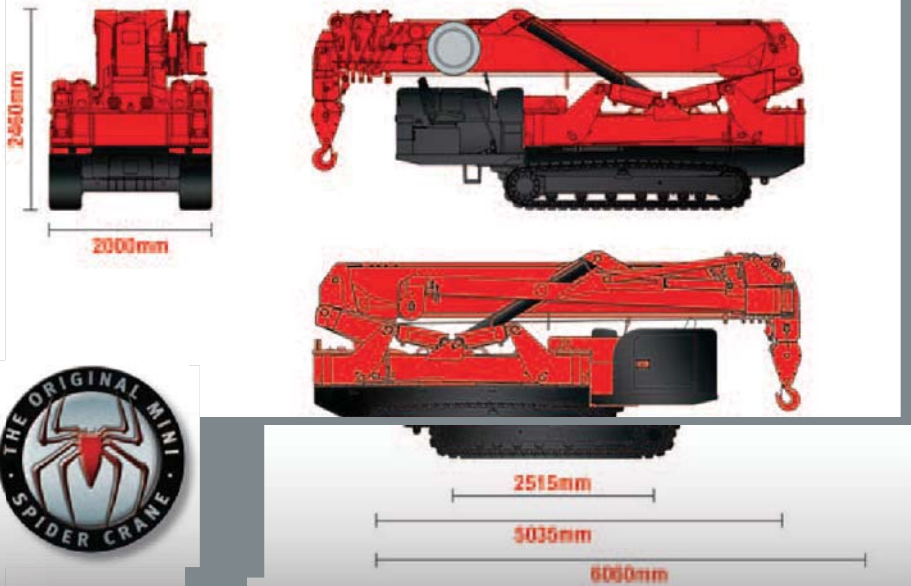

High resolution colour SLI



UNIC URW-1006 dashboard controls



CRANE SPECIFICATIONS

Crane capacity	capacity:	10.0t x 3.0m
Max working radius	max:	21.9m
Max lifting height	approx:	22.8m 27.6m with first stage fly jib 30.7m with second stage fly jib
Rope length	max:	30m (4 fall), 62m (2 fall), 128m (1 fall)
Dimensions	folded:	6060mm (l) x 2000mm (w) x 2460mm (h)
Weight	approx:	14000kg including optional electric pack and optional hydraulic fly jib
Point loadings	Due to the many variables involved, point loadings are only available on request	
Hook speed	approx:	10 - (16) m/min at 4th layer with 4-part line 20 - (32) m/min at 4th layer with 2-part line 40 - (64) m/min at 4th layer with 1-part line
Telescopic system	boom length: telescoping speed: boom type:	5.75 - 23.10m 17.35m/88 seconds 6 section hydraulically telescoping boom, hexagonal box construction
Derricking angle/speed	approx:	0 - 80°/44.0 seconds
Slewing angle/speed	approx:	360° (continuous) 1.3min rpm
Hydraulic outriggers	position: vertical: horizontal:	A double acting hydraulic cylinder with link system A double acting hydraulic cylinder, direct pushing type connected with hydraulic locking device A double acting hydraulic cylinder, direct pushing type connected with hydraulic locking device
Traction system	drive: travel speed: gradability: track ground length: track ground pressure: track width:	hydrostatic 2-speed, stepless forward and reverse 0 - 2.6km/h 23° 2515mm 68.2kPa (0.70kg/cm²) 400mm (city pad rubber on steel)
Engine	manufacturer: fuel: maximum output: starting method: tank capacity:	Yanmar diesel (electric dual power option) 29.8kW (40.5.0PS) / 2500min rpm electric 83 litres
Electric motor	power: voltage:	11kW 400v AC 50/60hz
Standard equipment	computer controlled moment limiter (safe load indicator) with high resolution colour display, multi-function operation by radio remote control with digital feedback, overwinding alarm, computer controlled intelligent voice warning system, intelligent throttle activation, automatic hook stow, overload warning alarms and lamps, working area limitation,	
Optional equipment	1 fall hook block, 2 fall hook block, mains electric dual power (400v), slew limitation, hydraulic fly jib 1000kg with single part line, data logging	



Outrigger interlocking device

URW-1006 (10.0t x 3.0m)



WORKING RANGE

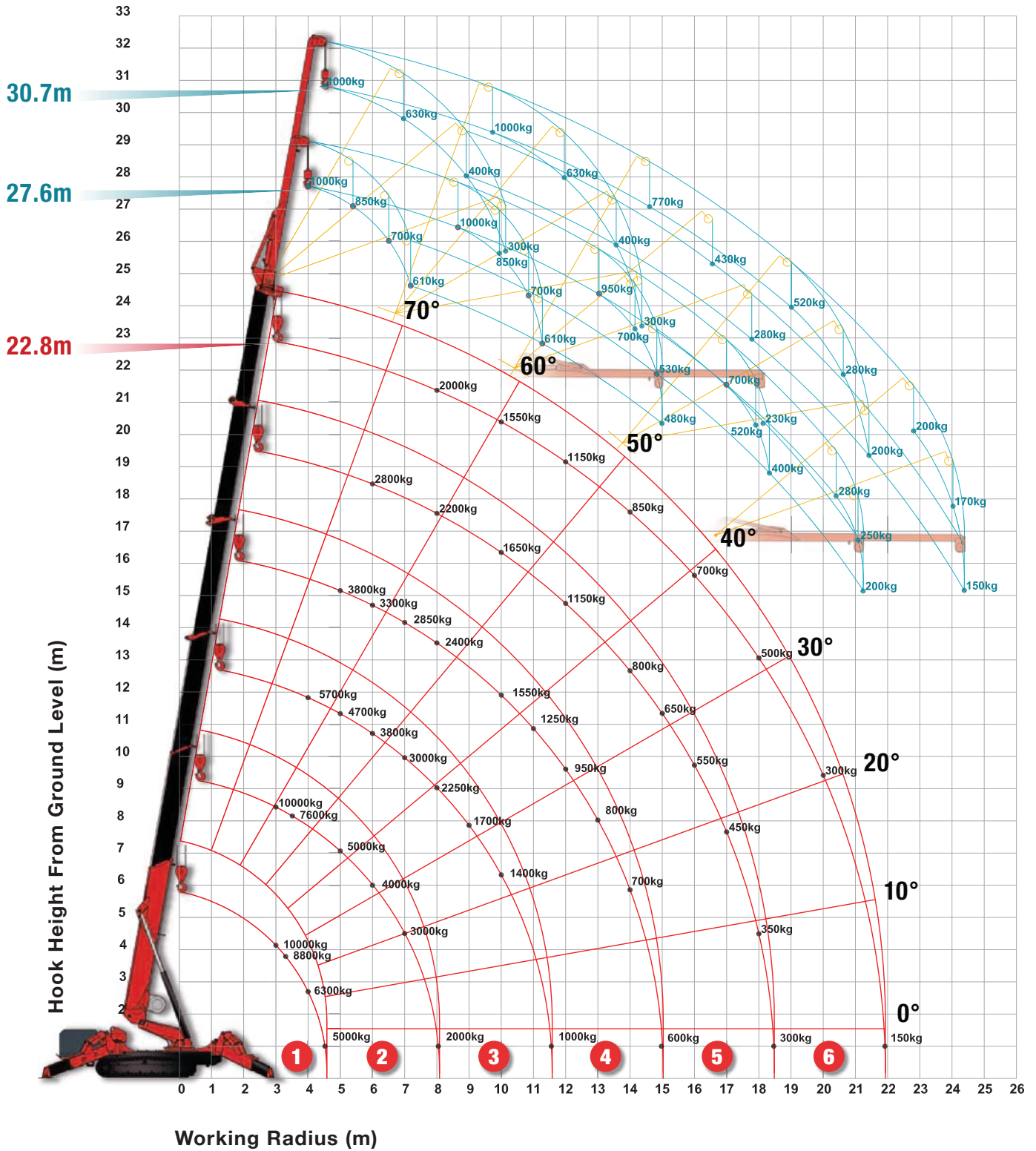

MINI SPIDER CRANE



OUTRIGGER POSITIONS & HOOK FALLS

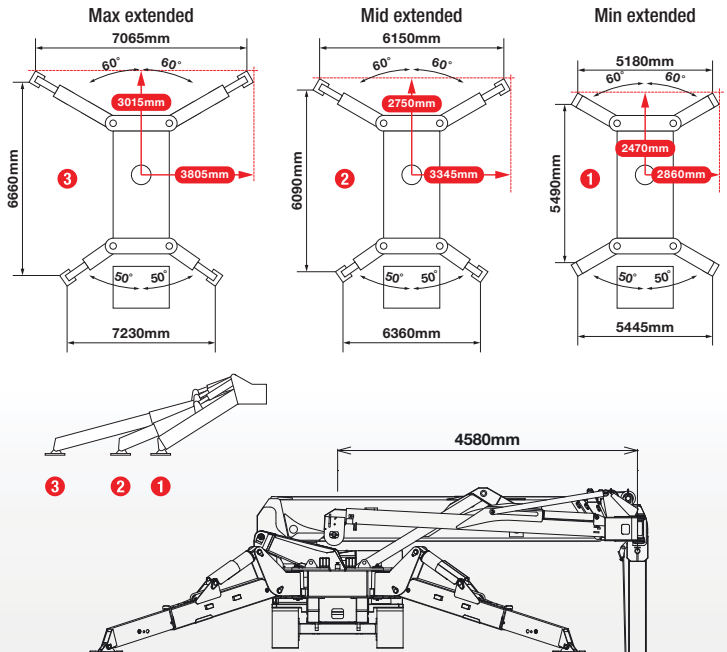
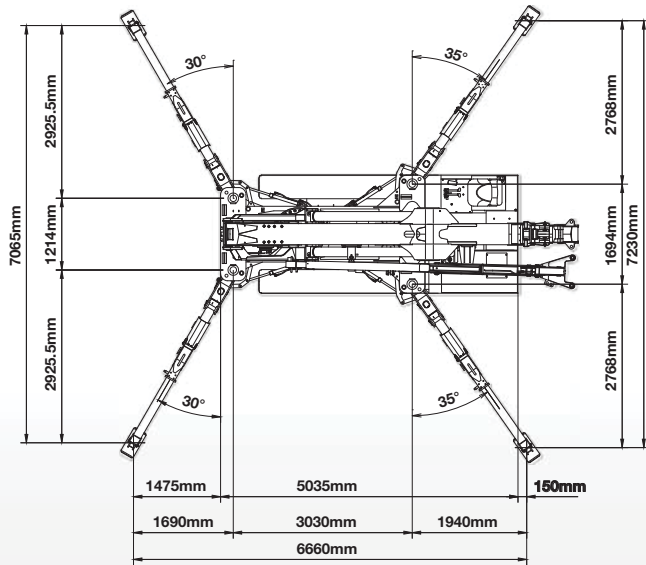

RATED LOADS

FIRST STAGE EXTENDED 5.8M BOOM LENGTH

Working radius	m	up to 2.5	3.0	3.3	3.5	4.0	4.58	
Outrigger	Max-extended	kg	10,000	10,000	8,800	7,600	6,300	5,000
	Mid-extended	kg	10,000	10,000	8,800	7,600	6,300	5,000
	Min-extended	kg	10,000	10,000	8,800	7,600	6,300	5,000

SECOND STAGE EXTENDED 5.8 - 9.2M BOOM LENGTH

Working radius	m	up to 2.5	3.0	3.5	4.0	5.0	6.0	7.0	8.08	
Outrigger	Max-extended	kg	10,000	10,000	7,600	6,300	5,000	4,000	3,000	2,000
	Mid-extended	kg	10,000	10,000	7,600	6,300	4,800	3,650	2,700	1,700
	Min-extended	kg	10,000	10,000	7,600	6,300	4,500	3,200	2,300	1,450

THIRD STAGE EXTENDED 9.2 - 12.7M BOOM LENGTH

Working radius	m	up to 4.0	5.0	6.0	7.0	8.0	9.0	10.0	11.58	
Outrigger	Max-extended	kg	5,700	4,700	3,800	3,000	2,250	1,700	1,400	1,000
	Mid-extended	kg	5,700	4,700	3,800	2,850	2,050	1,550	1,150	800
	Min-extended	kg	5,700	4,500	3,450	2,450	1,700	1,200	850	470

FOURTH STAGE EXTENDED 12.7 - 16.1M BOOM LENGTH

Working radius	m	up to 5.0	6.0	7.0	8.0	10.0	11.0	12.0	13.0	14.0	15.03	
Outrigger	Max-extended	kg	3,800	3,300	2,850	2,400	1,550	1,250	950	800	700	600
	Mid-extended	kg	3,800	3,300	2,850	2,400	1,550	1,150	880	700	550	400
	Min-extended	kg	3,800	3,200	2,600	2,060	1,160	850	600	420	250	100

FIFTH STAGE EXTENDED 16.1 - 19.5M BOOM LENGTH

Working radius	m	up to 6.0	8.0	10.0	12.0	14.0	15.0	16.0	17.0	18.0	18.48	
Outrigger	Max-extended	kg	2,800	2,200	1,650	1,150	800	650	550	450	350	300
	Mid-extended	kg	2,800	2,200	1,650	1,150	710	560	430	310	210	160
	Min-extended	kg	2,800	2,000	1,330	810	470	340	210	70	-	-

SIXTH STAGE EXTENDED 19.5 - 22.8M BOOM LENGTH

Working radius	m	up to 8.0	10.0	12.0	14.0	16.0	18.0	20.0	21.93	
Outrigger	Max-extended	kg	2,000	1,550	1,150	850	700	500	300	150
	Mid-extended	kg	2,000	1,550	1,150	780	470	230	80	-
	Min-extended	kg	2,000	1,450	950	580	320	110	-	-

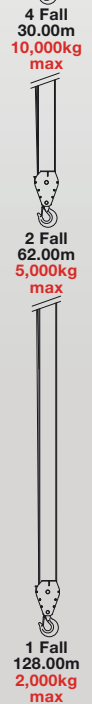

URW-1006

(10.0t x 3.0m)



FLY JIB WORKING RANGE

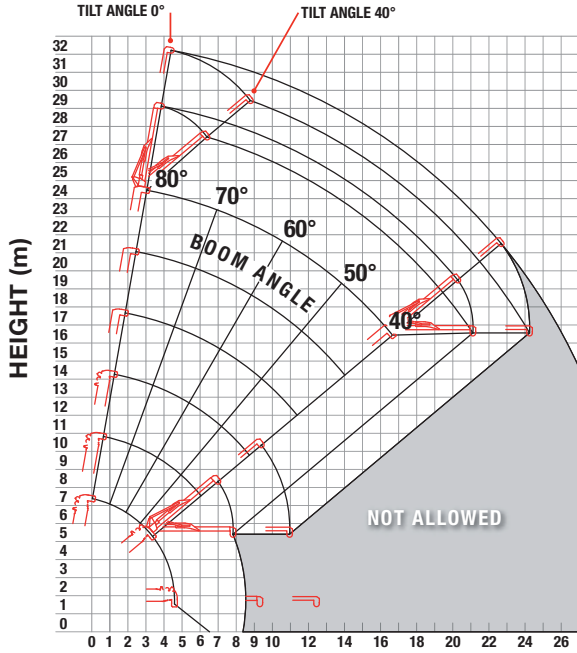

WORKING RADIUS (m) Tilt Angles 0° - 40°

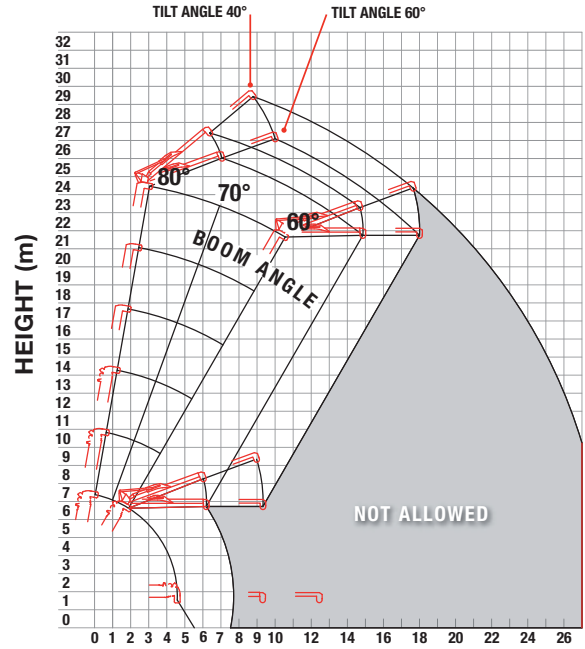

WORKING RADIUS (m) Tilt Angles 40° - 60°

Note: The above figures are based on a no-load condition and do not include the deflection of the boom.

FLY JIB NET RATED LOADS (kg) - ANGLE RATED

BOOM ANGLE	FLY JIB 1 (4.73m) - TILT ANGLES				FLY JIB 2 (7.87m) - TILT ANGLES			
	0°	20°	40°	60°	0°	20°	40°	60°
80°	1000	850	700	610	1000	630	400	300
70°	1000	850	700	610	1000	630	400	300
60°	950	700	530	480	770	430	280	230
50°	700	520	400		520	280	200	
40°	280	250	200		200	170	150	
30°	NOT ALLOWED				NOT ALLOWED			
20°								
10°								
0°								



High resolution colour SLI

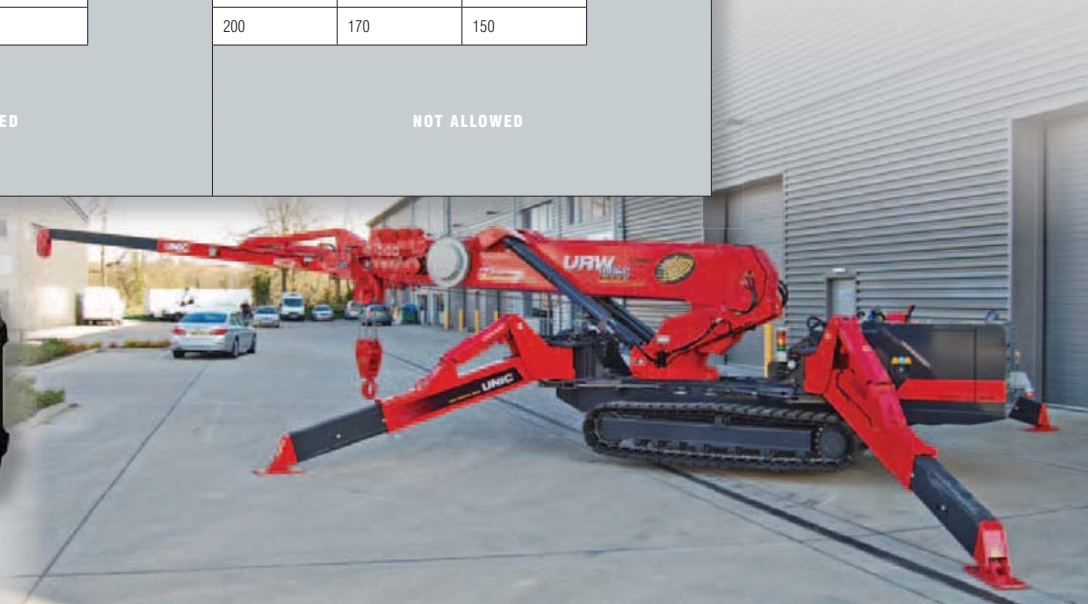

MINI SPIDER CRANE



PICK & CARRY WORKING RANGE

- Lifting Capacity** 1,500kg
- Working Radius** 2.5m
- Boom Length** Boom 1 and 1+2 only



High resolution colour SLI

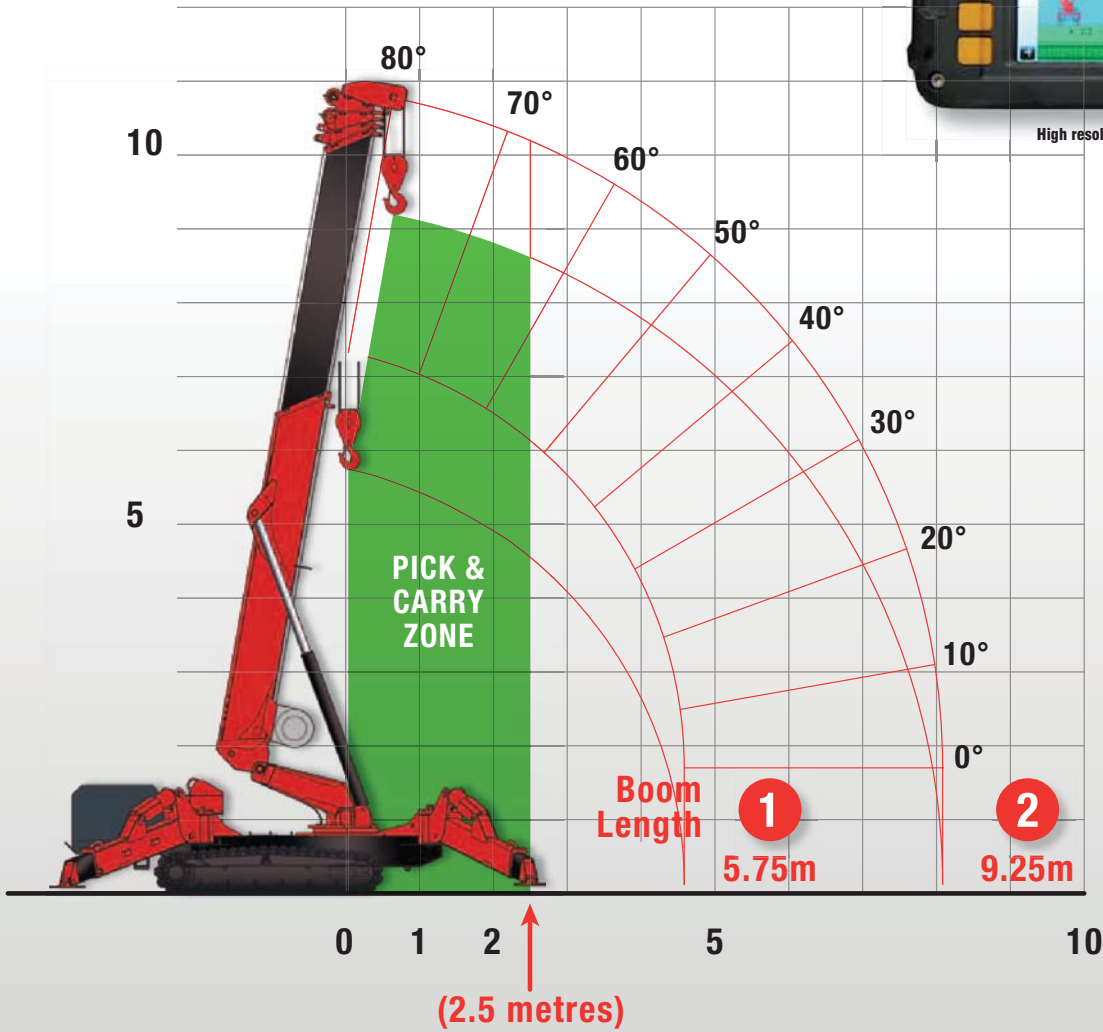

Safety pin and micro-switch keeps boom fixed in position



Outriggers extended for stability



Outriggers stowed to traverse a narrow opening

